

**PACKAGE DIMENSIONS**

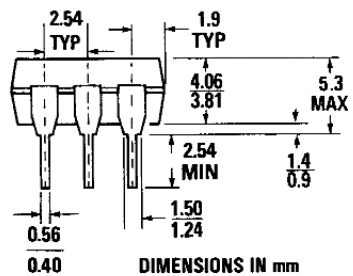

DIMENSIONS IN mm  
PACKAGE CODE K

ST1603A

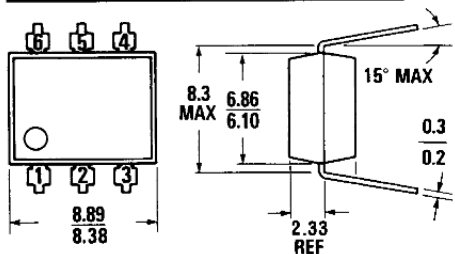
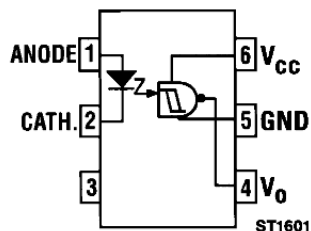

Equivalent Circuit

**DESCRIPTION**

The H11L series has a medium-to-high speed integrated circuit detector optically coupled to a gallium-arsenide infrared emitting diode. The output incorporates a Schmitt trigger, which provides hysteresis for noise immunity and pulse shaping. The detector circuit is optimized for simplicity of operation and utilizes an open collector output for maximum application flexibility.

**FEATURES**

- High data rate, 1 MHz typical (NRZ)
- Free from latch up and oscillation throughout voltage and temperature ranges.
- Microprocessor compatible drive
- Logic compatible output sinks 16 mA at 0.4 V maximum
- Guaranteed on/off threshold hysteresis
- High common mode rejection ratio
- Fast switching:  $t_r, t_f = 100$  ns typical
- Wide supply voltage capability, compatible with all popular logic systems
- Underwriters Laboratory (UL) recognized — file #E90700

**APPLICATIONS**

- Logic to logic isolator
- Programmable current level sensor
- Line receiver—eliminate noise and transient problems
- A.C. to TTL conversion—square wave shaping
- Digital programming of power supplies
- Interfaces computers with peripherals

**ABSOLUTE MAXIMUM RATINGS**

**TOTAL PACKAGE**

Storage temperature .....  $-55^{\circ}\text{C}$  to  $150^{\circ}\text{C}$   
 Operating temperature .....  $-55^{\circ}\text{C}$  to  $100^{\circ}\text{C}$   
 Lead solder temperature .....  $260^{\circ}\text{C}$  for 10 sec

**INPUT DIODE**

Power dissipation ( $25^{\circ}\text{C}$  ambient) ..... 100 mW  
 Derate linearly (above  $25^{\circ}\text{C}$  ambient) ...  $1.33$  mW/ $^{\circ}\text{C}$   
 Continuous forward current ..... 60 mA  
 Peak forward current (1  $\mu\text{s}$  pulse, 300pps) ..... 3 A  
 Reverse voltage ..... 6 V

**DETECTOR**

Power dissipation (at  $25^{\circ}\text{C}$  ambient) ..... 150 mW  
 Derate linearly (above  $25^{\circ}\text{C}$  ambient) ..... 2 mW/ $^{\circ}\text{C}$   
 $V_{AS}$  allowed range ..... 0 to 16 V  
 $V_{BS}$  allowed range ..... 0 to 16 V  
 $I_A$  output current ..... 50 mA

**ELECTRICAL CHARACTERISTICS** ( $T_A = 0-70^\circ\text{C}$  Unless Otherwise Specified)

**INDIVIDUAL COMPONENT CHARACTERISTICS**

PARAMETER	SYMBOL	MIN.	TYP.	MAX.	UNITS	TEST CONDITIONS
<b>INPUT DIODE</b>						
Forward voltage	$V_F$		1.1	1.5	V	$I_F = 10 \text{ mA}$
	$V_F$	0.75	0.95		V	$I_F = 0.3 \text{ mA}$
Reverse current	$I_R$			10	$\mu\text{A}$	$V_R = 3 \text{ V}$
Capacitance	$C_J$			100	pF	$V = 0, f = 1 \text{ MHz}$
<b>OUTPUT DETECTOR</b>						
Operating voltage range	$V_{CC}$	3		15	V	
Supply current	$I_{E(off)}$		1.0	5.0	mA	$I_F = 0, V_{CC} = 5 \text{ V}$
Output current, high	$I_{OH}$			100	$\mu\text{A}$	$I_F = 0, V_{CC} = V_O = 15 \text{ V}$

**TRANSFER CHARACTERISTICS**

CHARACTERISTIC	SYMBOL	MIN.	TYP.	MAX.	UNITS	TEST CONDITIONS
Supply current	$I_{E(on)}$		1.6	5	mA	$I_F = 10 \text{ mA}, V_{CC} = 5 \text{ V}$
Output voltage, low	$V_{OL}$		0.2	0.4	V	$R_L = 270 \Omega, V_{CC} = 5 \text{ V}, I_F = I_{F(on)} \text{ max.}$
Turn-on threshold current	(H11L1) $I_{F(on)}$		1.0	1.6	mA	$R_L = 270 \Omega, V_{CC} = 5 \text{ V}$
	(H11L2) $I_{F(on)}$		6.0	10.0	mA	$R_L = 270 \Omega, V_{CC} = 5 \text{ V}$
	(H11L3) $I_{F(on)}$		3.0	5.0	mA	$R_L = 270 \Omega, V_{CC} = 5 \text{ V}$
Turn-off threshold current	$I_{F(off)}$	0.3	1.0		mA	$R_L = 270 \Omega, V_{CC} = 5 \text{ V}$
Hysteresis ratio	$I_{F(off)}/I_{F(on)}$	0.50	0.75	0.90		$R_L = 270 \Omega, V_{CC} = 5 \text{ V}$



## MICROPROCESSOR COMPATIBLE GaAs SCHMITT TRIGGER OPTOCOUPLEDERS

<b>DYNAMIC CHARACTERISTICS</b>						
PARAMETER	SYMBOL	MIN.	TYP.	MAX.	UNITS	TEST CONDITIONS
<b>SWITCHING SPEED</b>						
Turn-on time	$t_{ON}$		1.0		$\mu S$	$C=0, R_E=1.2\text{ k}\Omega$
	$t_{ON}$		0.65		$\mu S$	$C=270\text{ pF}, R_E=1.2\text{ k}\Omega$ $f \leq 100\text{ KHz}, t_p \geq 1\ \mu S$
Fall time	$t_f$		0.1		$\mu S$	$C=0, R_E=1.2\text{ k}\Omega$
	$t_f$		0.05		$\mu S$	$C=270\text{ pF}, R_E=1.2\text{ k}\Omega$ $f \leq 100\text{ KHz}, t_p \geq 1\ \mu S$
Turn-off time	$t_{OFF}$		2.0		$\mu S$	$C=0, R_E=1.2\text{ k}\Omega$
	$t_{OFF}$		1.20		$\mu S$	$C=270\text{ pF}, R_E=1.2\text{ k}\Omega$ $f \leq 100\text{ KHz}, t_p \geq 1\ \mu S$
Rise time	$t_r$		0.1		$\mu S$	$C=0, R_E=1.2\text{ k}\Omega$
	$t_r$		0.07		$\mu S$	$C=270\text{ pF}, R_E=1.2\text{ k}\Omega$ $f \leq 100\text{ KHz}, t_p \geq 1\ \mu S$
Data rate			1.0*		MHz	

<b>ISOLATION CHARACTERISTICS</b>						
CHARACTERISTIC	SYMBOL	MIN.	TYP.	MAX.	UNITS	TEST CONDITIONS
Surge isolation voltage	$V_{ISO}$	7500			$V_{PEAK}$	1 Minute
Surge isolation voltage	$V_{ISO}$	5300			$V_{RMS}$	1 Minute

\*Maximum data rate will vary depending on the bias conditions and is usually highest when  $R_E$  and  $C$  are matched to  $I_{F(ON)}$  and  $V_{CC}$  is between 3 and 15 V. With this optimized bias, most units will operate over 1.5 MHz (NRZ).

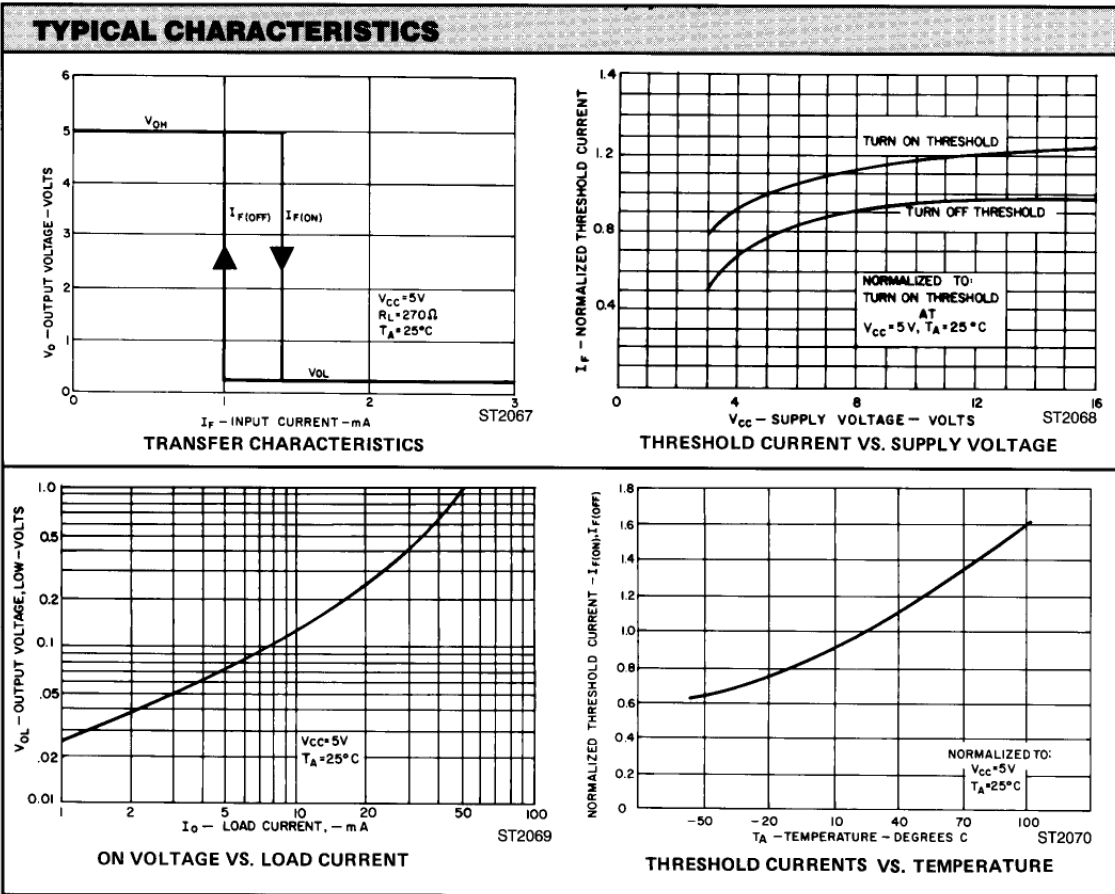
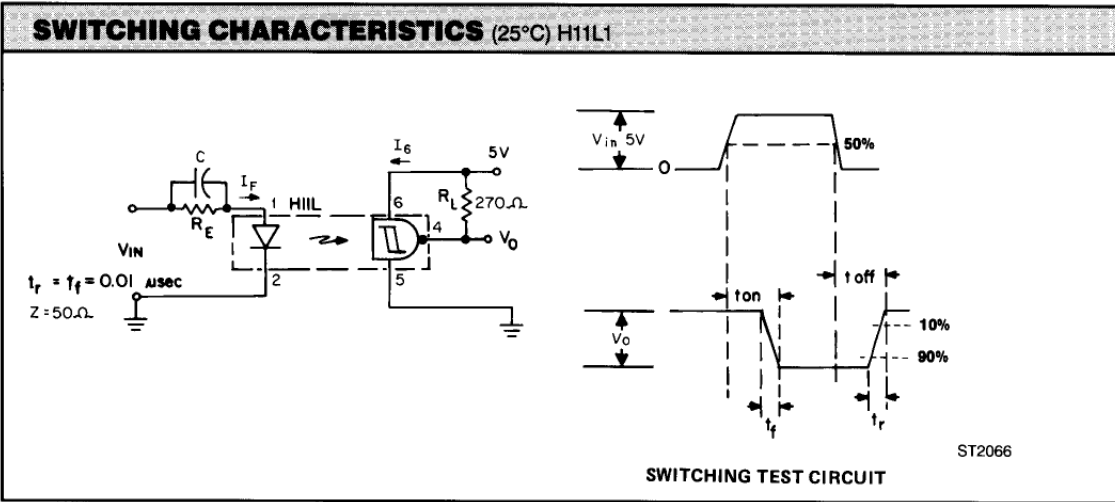

**TYPICAL CHARACTERISTICS (Cont'd)**

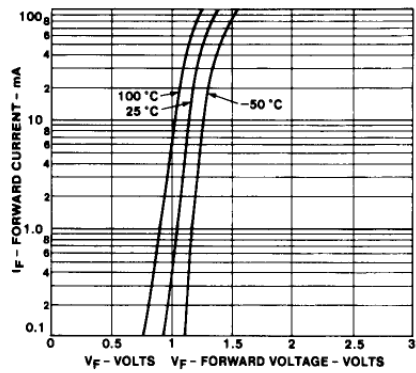

ST2015

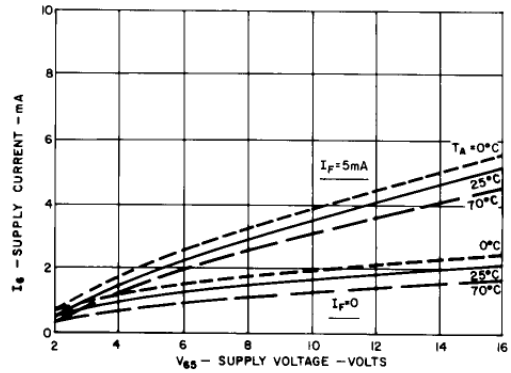

ST2016

**FORWARD VOLTAGE VS. FORWARD CURRENT**

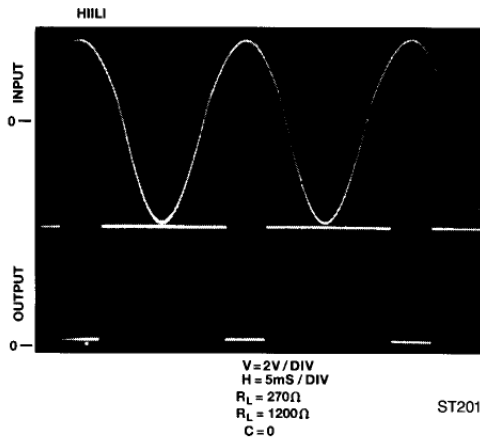

ST2017

**SUPPLY CURRENT VS. SUPPLY VOLTAGE**

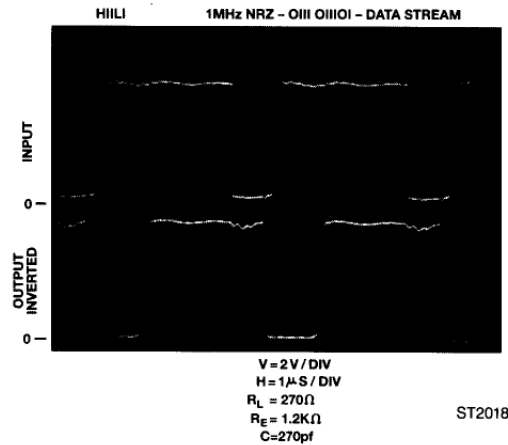

ST2018

**TYPICAL APPLICATION**

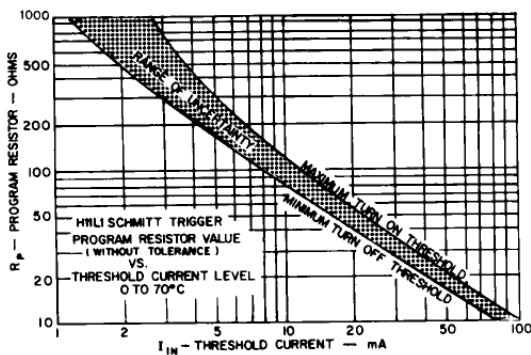

ST2019

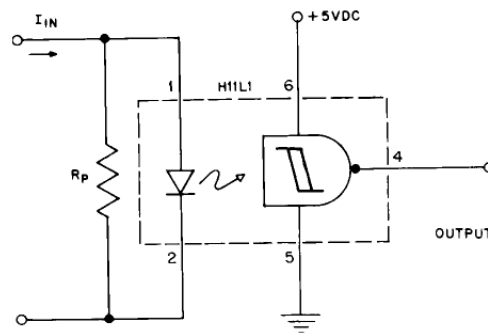

**PROGRAMMABLE CURRENT  
THRESHOLD SENSING CIRCUIT**



## MICROPROCESSOR COMPATIBLE GaAs SCHMITT TRIGGER OPTOCOUPLEDERS

---

### DISCLAIMER

FAIRCHILD SEMICONDUCTOR RESERVES THE RIGHT TO MAKE CHANGES WITHOUT FURTHER NOTICE TO ANY PRODUCTS HEREIN TO IMPROVE RELIABILITY, FUNCTION OR DESIGN. FAIRCHILD DOES NOT ASSUME ANY LIABILITY ARISING OUT OF THE APPLICATION OR USE OF ANY PRODUCT OR CIRCUIT DESCRIBED HEREIN; NEITHER DOES IT CONVEY ANY LICENSE UNDER ITS PATENT RIGHTS, NOR THE RIGHTS OF OTHERS.

### LIFE SUPPORT POLICY

FAIRCHILD'S PRODUCTS ARE NOT AUTHORIZED FOR USE AS CRITICAL COMPONENTS IN LIFE SUPPORT DEVICES OR SYSTEMS WITHOUT THE EXPRESS WRITTEN APPROVAL OF THE PRESIDENT OF FAIRCHILD SEMICONDUCTOR CORPORATION. As used herein:

1. Life support devices or systems are devices or systems which, (a) are intended for surgical implant into the body, or (b) support or sustain life, and (c) whose failure to perform when properly used in accordance with instructions for use provided in the labeling, can be reasonably expected to result in a significant injury of the user.
2. A critical component in any component of a life support device or system whose failure to perform can be reasonably expected to cause the failure of the life support device or system, or to affect its safety or effectiveness.